



Arc Welding Safety

Guide for Safe Arc Welding

www.lincolnelectric.com

LINCOLN[®]
ELECTRIC
THE WELDING EXPERTS[®]

Safety Practices in Welding

INTRODUCTION

Arc welding is a safe occupation when sufficient measures are taken to protect the welder from potential hazards. When these measures are overlooked or ignored, however, welders can encounter such dangers as electric shock, overexposure to fumes and gases, arc radiation, and fire and explosion; which may result in serious, or even fatal injuries.

This bulletin is written with the arc welding operator in mind, containing both mandatory safety practices and those based on shop experience. Be sure to read ANSI Z49.1, and refer to the other publications listed at the end of the bulletin for more detailed information on specific topics of arc welding safety, as well as the manufacturers' instructions and material safety data sheets (MSDS's).

Important Note:

So that you can protect yourself against these hazards, every welder should be familiar with American National Standard ANSI Z49.1, "Safety in Welding and Cutting," and should follow the safety practices in that document. Z49.1 is now available for download at no charge at:

<http://www.lincolnelectric.com/community/safety/> or at the AWS website <http://www.aws.org>.

Download and read it!

PERSONAL PROTECTIVE EQUIPMENT

Protective Clothing

Welders, like firemen, must wear clothing to protect them from being burned. Of all injuries to welders, burns are the most common due to sparks landing on bare skin. Welding arcs are very intense and can cause burns to skin and eyes with just a few minutes of exposure.

The actual gear varies with the job being performed, but generally **protective clothing** must allow freedom of movement while providing adequate coverage against burns from sparks, weld spatter, and arc radiation. Many types of clothing will protect you from ultra-violet radiation exposure, which appears as a skin burn (much like sunburn). Under the worst conditions, however, severe burns and skin cancer may result from excessive radiation.

Because of its durability and resistance to fire, wool clothing is suggested over synthetics (which should never be worn because it melts when exposed to extreme heat) or cotton, unless it is specially treated for fire protection. If possible, keep your clothes clean of grease and oil, as these substances may ignite and burn uncontrollably in the presence of oxygen.

Avoid rolling up your sleeves and pant-cuffs, because sparks or hot metal could deposit in the folds; also, wear your trousers outside your work boots, not tucked in, to keep particles from falling into your boots. While we're on the subject, we suggest

leather high-tops with steel toes (especially when doing heavy work).

Other protective wear for heavy work or especially hazardous situations includes: flame-resistant suits, aprons, leggings, leather sleeves/shoulder capes, and caps worn under your helmet.

Heavy, flame-resistant gloves, such as leather, should **always** be worn to protect your hands from burns, cuts, and scratches. In addition, as long as they are dry and in good condition, they will offer some insulation against electric shock.

As to preventing electric shock, the key word is **dry!** We'll have more on the subject later, but for now keep in mind that moisture can increase the potential for and severity of electric shock.

When working in wet conditions, or when perspiring heavily, you must be even more careful to insulate your body from electrically "live" parts and work on grounded metal.



WARNING



ARC RAYS can burn.

- Wear eye, ear and body protection.

Note To Arc Welding Educators and Trainers:

This Arc Welding Safety brochure may be freely copied for educational purposes if distributed to welders and welding students at no additional charge.

ARC RAYS

It is essential that your **eyes are protected** from radiation exposure. Infrared radiation has been known to cause retinal burning and cataracts. And even a brief exposure to ultraviolet (UV) radiation can cause an eye burn known as “welder’s flash.” While this condition is not always apparent until several hours after exposure, it causes extreme discomfort, and can result in swelling, fluid excretion, and temporary blindness. Normally, welder’s flash is temporary, but repeated or prolonged exposure can lead to permanent injury of the eyes.

Other than simply not looking at an arc, the primary preventive measure you can take is to use the proper shade lens in your helmet. Refer to the lens shade selector chart in Supplement 1 for the recommended shade numbers for various arc welding processes. The general rule is to choose a filter too dark to see the arc, then move to lighter shades without dropping below the minimum rating. The filters are marked as to the manufacturer and shade number, the impact-resistant variety are marked with an “H.”

Helmets and hand-held face shields (see Figure A) offer the most complete shading against arc radiation. The shade slips into a window at the front of the shield so that it can be removed and replaced easily. The shields are made from a hard plastic or fiberglass to protect your head, face, ears, and neck from electric shock, heat, sparks, and flames. You should also use safety glasses with side shields or goggles to protect your eyes from flying particles.

Visible light can also be harmful, but it is easy to tell if the light is dangerous: if it hurts to look at, then it’s too bright. The same is true for infrared radiation: it can usually be felt as heat. However, there’s no real way for you to tell if you’re being over exposed to UV radiation, so just don’t take chances: always wear eye protection (see Supplement 1 for recommended lens shade numbers).

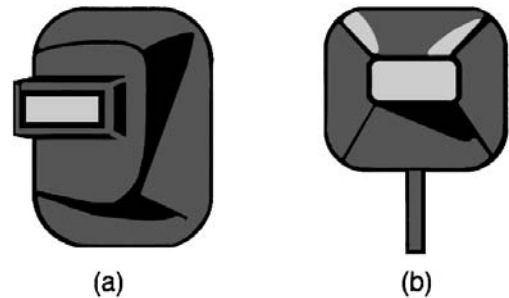

Figure A. A helmet (a) required for protecting the welder’s eyes and face and (b) a hand-held face shield that is convenient for the use of foremen, inspectors, and other spectators.

NOISE

There are two good reasons to **wear ear muffs or plugs**:

- a) to keep flying sparks or metal out of your ears; and
- b) to prevent hearing loss as a result of working around noisy arc welding equipment, power sources, and processes (like air carbon arc cutting or plasma arc cutting).

As with radiation exposure to the eyes, the length and number of times that you are exposed to high levels of noise determine the extent of the damage to your hearing, so be sure to avoid repeated exposure to noise. If it is not possible to reduce the level of noise at the source (by moving either yourself or the equipment, utilizing sound shields, etc.), then you should wear adequate ear protection.

If the noise in your work area becomes uncomfortable, causing a headache or discomfort of the ears, you could be damaging your hearing and should immediately put on ear muffs or plugs.

In fact, the use of ear protection at all times is a good idea, as hearing loss is both gradual and adds up over time. Damage to your hearing may not be noticed until you have a complete hearing test, and then it could be too late.

INSPECTION AND MAINTENANCE OF EQUIPMENT AND WORK

Before starting any arc welding operation, you should make a **complete inspection** of your equipment. All it takes on your part is 5-10 minutes before you turn on your welder; is that too much to spend in preventing injury to yourself or your co-workers?

To begin with:

- Have you read the instruction manual and do you understand the instructions? The instruction manual for your welder is available upon request to your welding distributor or the manufacturer. Manuals for Lincoln Electric welders may be downloaded from lincolnelectric.com at no charge.
- Have you read the warnings and instructions on the equipment nameplates and decals as well as the consumables labels and material safety data sheets? (For older equipment see Supplement 5 to request a FREE Warning Label.)

For the welder:

- Are all the connections tight, including the earth ground?
- OSHA regulations require output terminals to be insulated. Rubber boots are available for that purpose.
- Are the electrode holder and welding cable well insulated and in good condition?
- Are the settings correct for the job you're about to begin?

For an engine-driven welder:

- Is it running OK?
- Are all the hoses on tight?
- Is the fuel cap on tight?
- Is the engine leaking fuel or oil? Some jobsites look for this and may refuse entry if your engine is leaking.
- Is the original enclosure and fan guarding in place? Check with your welding equipment distributor if you are unsure. (See Supplement 6.)

For the work in general: (See also Supplements 4 and 7)

- Are the work area conditions such that normal safety precautions can be observed or must special equipment (i.e., ventilation, exhaust, or respirator, welding equipment, protective equipment, safety equipment) or procedures be used?
- Many jobsites require permits for any welding or cutting. Be sure you have any permits you will need.
- If you will be working in a confined space, many special OSHA regulations and jobsite requirements may apply in addition to the arc welding precautions in this brochure. Understand which of these apply to your jobsite and comply with them.
- Are the cables the right size for your job? Be sure any damaged cable insulation is repaired.
- Are they spread out and run neatly to prevent overheating?
- Is the gas cylinder connected properly?
- Is the cylinder secure?



- Is the work stable and easy to reach from where you're standing?
- Is the Work Lead connected securely?
- Is there enough dry insulation between your body and the work piece?
- Is there adequate ventilation in your work area?

Take some personal responsibility for your own safety. Notify your supervisor if equipment is in need of repair or not working properly or any unsafe condition. You have the most to lose if you get hurt. Don't allow yourself to work in a hazardous situation without taking appropriate safety precautions.

If the hazard is serious and cannot be corrected readily, the machine should be shut down until the needed repairs are made. If the problem is limited to the outside of the welder, such as a loose connection or a damaged cable that needs to be replaced, **disconnect power to the welder** and correct the problem per the manufacturers instructions in the operating/service manual. If the hazard requires repairs to the inside of the welder or to the electrical input supply lines, call a service technician or an electrician. Never attempt to make these repairs if you are untrained.

Important Safety Note:

Consider whether the area in which you will be working creates or increases the level of hazard to you thus requiring special procedures or equipment. Factors such as electrical safety, fume ventilation/exhaust and risk of fire or explosion may be affected. See later sections on those topics and other documents in "Bibliography and Suggested Reading" for further information.

CARE AND CLEANING OF THE WORK AREA

Keeping the area around your work neat is as important as maintaining your equipment. Perhaps even more-so, as the risk of injury is amplified by the larger group of people involved. You may have already inspected your equipment and found it to be OK, but all your caution won't matter when, for example, a co-worker trips over your cable, causing you, and/or the people around you, to be injured by shock, hot metal, or from falling.

Keep all your equipment, cables, hoses, cylinders, etc. out of any traffic routes such as doors, hallways, and ladders. A good practice is to avoid clutter ... and **clean up your work area** when you're done! Not only will it help to protect yourself and others, you'll find it much easier for you to work efficiently.

Also, bear in mind that while you're paying attention to your work, other welders may be preoccupied with their own tasks and not watching where they're going. So be sure that there are protective screens in place, just in case somebody happens to be passing into your work area or walks into a shower of sparks or spatter.

GAS CYLINDERS

Because of the high pressure gas in cylinders, you must pay particularly close attention to their storage and use. Examine the cylinders as you did the rest of your equipment; check the cylinder label to make sure it is the correct shielding gas for the process, and that the regulators, hoses, and fittings are the right ones for that gas and pressure, and are in good condition.

Cylinders must be secured in an upright position, with the valve caps in place, in an area away from combustibles and fuels, and safeguarded from damage, heat, and flames. When in use, keep them out of traffic routes and flying sparks, with all hoses run neatly to the welding area. Never allow the electrode or other "electrically hot" parts of your welder to touch a cylinder. "Crack" the valve open to prevent dirt from entering the regulator; open

the cylinder valve only when standing to one side of the cylinder, away from welding or other sources of ignition. Return damaged cylinders to the supplier. Refer to the Compressed Gas Association pamphlet P-1, "Safe Handling of Gas Cylinders," for further information.



WARNING



CYLINDER may explode if damaged.

- **Keep cylinder upright and chained to support.**
- **Never allow welding electrode to touch cylinder.**

Electric and Magnetic Fields

Electric current flowing through any conductor causes localized Electric and Magnetic Fields (EMF). Welding current creates EMF fields around welding cables and welding machines. EMF fields may interfere with some pacemakers, and welders having a pacemaker should consult their physician before welding. Exposure to EMF fields in welding may have other health effects which are now not known. All welders should use the following procedures in order to minimize exposure to EMF fields from the welding circuit:

- Route the electrode and work cables together – Secure them with tape when possible.
- Never coil the electrode lead around your body.
- Do not place your body between the electrode and work cables. If the electrode cable is on your right side, the work cable should also be on your right side.
- Connect the work cable to the workpiece as close as possible to the area being welded.
- Do not work next to welding power source.

SPECIFIC CONCERNS

Possible Shock Hazards

The hazard of electric shock is one of the most serious and immediate risks facing you as a welder. Contact with metal parts which are “electrically hot” can cause injury or death because of the effect of the shock upon your body or a fall which may result from your reaction to the shock. The electric shock hazard associated with arc welding may be divided into two categories which are quite different:

- Primary Voltage Shock (i.e., 230, 460 volts); and
- Secondary Voltage Shock (i.e., 20-100 volts).

⚠ WARNING



HIGH VOLTAGE can kill.

- Do not operate with covers removed.
- Disconnect input power before servicing.
- Do not touch electrically live parts.

The **primary voltage shock** is very hazardous because it is much greater voltage than the welder secondary voltage. You can receive a shock from the primary (input) voltage if you touch a lead inside the welder with the **power to the welder** “on” while you have your body or hand on the welder case or other grounded metal. Remember that turning the welder power switch “off” does not turn the power off **inside the welder**. To turn the power inside the welder “off”, the input power cord must be unplugged or the power disconnect switch turned off. You should never remove fixed panels from your welder; in fact, always have a qualified technician repair your welder if it isn’t working properly. Also, your welder should be installed by a qualified electrician so it will be correctly wired for the primary voltage which supplies it power and so the case will be connected to an earth ground. When electrical supply lines are connected to a

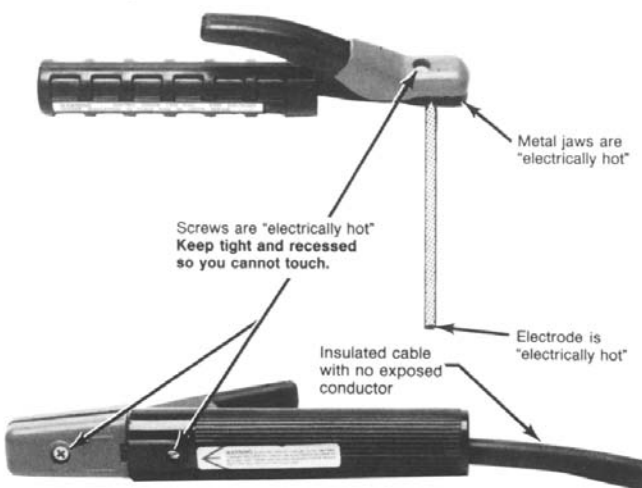

Figure B. Always inspect your electrode holder before turning the welder on.

welder, check the welder capacity nameplate and connection instructions to be sure the input is the correct phase (single phase or three phase) and voltage. Many welders may be set up for single phase or three phase and for multiple input voltages. Be certain the welder is set up for the electrical supply to which it is connected. **Only a qualified electrician should connect input power.** The case must be grounded so that if a problem develops inside the welder a fuse will blow, disconnecting the power and letting you know that repair is required. Never ignore a blown fuse because it is a warning that something is wrong.

⚠ WARNING



ELECTRIC SHOCK can kill.

- Do not touch electrically live parts or electrode with skin or wet clothing.
- Insulate yourself from work and ground.

If welding must be performed under electrically hazardous conditions (in damp locations or while wearing wet clothing; on metal structures such as floors, gratings or scaffolds; when in cramped positions such as sitting, kneeling or lying, if there is a high risk of unavoidable or accidental contact with the work piece or ground) use the following equipment:

- **Semiautomatic DC Constant Voltage Welder**
- **DC Manual (Stick) Welder**
- **AC Welder with Reduced Voltage Control**

A **secondary voltage shock** occurs when you touch a part of the **electrode circuit** — perhaps a bare spot on the electrode cable — at the same time another part of your body is touching the metal upon which you’re welding (work). To receive a shock your body must touch both sides of the welding circuit — electrode and work (or welding ground) — at the same time. To prevent secondary voltage shock, you must develop and use safe work habits. Remember the voltage at the electrode is highest when you are **not** welding (open circuit voltage).

- Wear **dry** gloves in good condition when welding.
- Do not touch the electrode or metal parts of the electrode holder with skin or wet clothing.
- Keep **dry** insulation between your body (including arms and legs) and the metal being welded or ground (i.e., metal floor, wet ground).
- Keep your welding cable and electrode holder in good condition. Repair or replace any damaged insulation.

These rules are basic to welding and you should already know them. Check out the warning on your welder or electrode box next time you weld. You will probably not have a shock while welding if you follow these rules.

Though it may be more difficult to follow the rules under some conditions, the rules still apply. Keep your gloves **dry** even if you have to keep an extra pair. Use plywood, rubber mats, or some other **dry** insulation to stand or lie upon. Insulate your body from the metal you are welding. Don't rest your body, arms, or legs on the workpiece, especially if your clothing is wet or bare skin is exposed (and it should not be if you are dressed properly). In addition to the normal safety precautions, if welding must be performed under electrically hazardous conditions (in damp locations or while wearing wet clothing; on metal structures such as floors, gratings or scaffolds; when in cramped positions such as sitting, kneeling or lying, if there is a high risk of unavoidable or accidental contact with the work piece or ground) use the following equipment:

- Semiautomatic DC Constant Voltage Welder
- DC Manual (Stick) Welder
- AC Welder with Reduced Voltage Control

The condition of your electrode holder and electrode cable is also very important. The plastic or fiber insulation on the electrode holder protects you from touching the metal "electrically hot" parts inside. Always inspect your electrode holder before turning the welder on. Replace the holder if it is damaged — don't try to repair it unless you have replacement parts.

The same is true of the electrode cable except that when not replaced it may be repaired using good electrical tape. If your cable has been repaired, be sure to check and see that the tape is secure before you turn the welder on.

Remember, a stick electrode is always "electrically hot" when the welder is on — treat it with respect. If you do experience a shock, think of it as a warning — check your equipment, work habits and work area to see what is wrong before continuing to weld.



WARNING



WELDING SPARKS can cause fire or explosion.
• Keep flammable material away.

Fire Hazards

Because of the extreme temperatures associated with any arc welding process, you should always be aware of fire hazards. The heat of the welding arc can reach temperatures of 10,000°F, but this heat in itself is not generally a fire hazard. The danger of fire actually results from the effects of this intense heat upon your work and in the form of **sparks and molten metals**. Because these can spray up to 35 feet from your work, you must

recognize and protect combustible materials from the welding arc, sparks and spatter. It is also important to be sure the work is not in contact with any combustible which it may ignite when heated. These materials fall into three categories: liquid (gasoline, oil, paints, and thinners); solid (wood, cardboard, and paper); and gaseous (acetylene and hydrogen).

Watch where the sparks and metals are falling from your work: if there are flammable materials including fuel or hydraulic lines in your work area and you can't move either your work or the combustible substances, put a fire-resistant shield in place. If you're welding above the ground or off a ladder, make sure that there are no combustibles underneath. Also, don't forget about your co-workers, and everybody else who may be in the work area, as they probably wouldn't appreciate being hit with slag or sparks from your work.

Particular care must be taken when welding or cutting in dusty locations. Fine dust particles may readily oxidize (burn) and without warning result in a flash fire or even an explosion when exposed to the welding arc or even sparks.

If you are not sure of the combustible or volatile nature of residue or dust in the work area, no welding or cutting should take place until a responsible person has inspected the area and given approval for the work.

Before you start welding, inspect the surface of your work, looking for flammable coatings or any unknown substances that would ignite when heated. Because of the extreme fire and explosion hazards inherent to welding on or around containers and piping that may have combustible materials, such work should be handled only by experienced welders who review and follow the safety practices recommended in the American Welding Society document F4.1, "Recommended Safe Practices for the Preparation for Welding and Cutting of Containers and Piping Which Had Held Hazardous Substances."

Know where the fire alarms and fire extinguishers are located, and check the pressure gauges so you don't rely upon one that's empty. If there are none in the area, make sure that you have access to fire hoses, sand buckets, fire-resistant blankets, or other fire fighting equipment. If you're welding within 35 feet or so of flammable materials, you should have a fire watcher to see where your sparks are flying, and to grab an extinguisher or alarm if needed. Both you and the fire watcher should wait for a half hour after all welding is finished to find and put out any smoldering fires that may have resulted from your welding.

As with other emergencies that may result from welding accidents, the first rule is: don't panic. Depending on the size of the fire, sound the fire alarm to warn others and call the fire department; shut off your welder; and get to the fire exits as quickly as possible.

**WARNING**

FUMES & GASES can be dangerous to your health

- **Keep fumes and gases from your breathing zone and general area.**
- **Keep your head out of the fumes.**
- **Use enough ventilation or exhaust at the arc, or both, to keep fumes and gases from your breathing zone and general area.**

Fumes and Gases

Because of the variables involved in fume and gas generation from arc welding, cutting and allied processes (such as the welding process and electrode, the base metal, coatings on the base metal, and other possible contaminants in the air), we'll have to treat the subject in a rather general way, lumping all but the more hazardous situations together. The precautions we describe will hold true for all arc welding processes.

The **fume plume** contains solid particles from the consumables, base metal, and base metal coating. For common mild steel arc welding, depending on the amount and length of exposure to these fumes, most immediate or short term effects are temporary, and include symptoms of burning eyes and skin, dizziness, nausea, and fever. For example, zinc fumes can cause metal fume fever, a temporary illness that is similar to the flu.

Long-term exposure to welding fumes can lead to siderosis (iron deposits in the lungs) and may affect pulmonary function. Bronchitis and some lung fibrosis have been reported.

Some consumables contain certain compounds in amounts which may require special ventilation and/or exhaust. These Special Ventilation products can be identified by reading the labels on the package. If Special Ventilation products are used indoors, use local exhaust. If Special Ventilation products are used outdoors, a respirator may be required. Various compounds, some of which may be in welding fume, and reported health effects, in summary, are:

Barium: Soluble barium compounds may cause severe stomach pain, slow pulse rate, irregular heart beat, ringing of the ears, convulsions and muscle spasms. In extreme cases can cause death.

Cadmium also requires extra precautions. This toxic metal can be found on some steel and steel fasteners as a plating, or in silver solder. Cadmium fumes can be fatal even under brief overexposures, with symptoms much like those of metal fume fever. These two conditions should **not** be confused. Overexposure to cadmium can be enough to cause fatalities, with symptoms appearing quickly, and, in some circumstances, death a few days later.

Chromium: Chromium is on the IARC (International Agency for Research on Cancer) and NTP (National Toxicology Program) lists chromium as posing a carcinogenic risk to humans. Fumes from the use of stainless steel, hardfacing and other types of consumables contain chromium and/or nickel. Some forms of these metals are known or suspected to cause lung cancer in processes other than welding and asthma has been reported. Therefore, it is recommended that precautions be taken to keep exposures as low as possible. OSHA recently adopted a lower

PEL (Permissible Exposure Limit) for chromium (see Supplement 3). The use of local exhaust and/or an approved respirator may be required to avoid overexposure.

Coatings on the metal to be welded, such as paint, may also contain toxic substances, such as lead, chromium and zinc. In general, it is always best to remove coatings from the base metal before welding or cutting.

Cobalt: Exposure to cobalt can cause respiratory disease and pulmonary sensitization. Cobalt in metallic form has been reported to cause lung damage.

Copper: Prolonged exposure to copper fume may cause skin irritation or discoloration of the skin and hair.

Manganese: Manganese overexposure may affect the central nervous system, resulting in poor coordination, difficulty in speaking, and tremor of arms or legs. This condition is considered irreversible.

Nickel: Nickel and its compounds are on the IARC (International Agency for Research on Cancer) and NTP (National Toxicology Program) lists as posing a carcinogenic risk to humans.

Silica: Crystalline silica is present in respirable dust form submerged arc flux. Overexposure can cause severe lung damage (silicosis).

Zinc: Overexposure to zinc (from galvanized metals) may cause metal fume fever with symptoms similar to the common flu.

The **gases** that result from an arc welding process also present potential hazard. Most of the shielding gases (argon, helium, and carbon dioxide) are non-toxic, but, as they are released, they **displace oxygen** in your breathing air, causing dizziness, unconsciousness, and death, the longer your brain is denied the oxygen it needs. Carbon monoxide can also be developed and may pose a hazard if excessive levels are present.

The **heat and UV radiation** can cause irritation to the eyes and lungs. Some degreasing compounds such as trichlorethylene and perchlorethylene can decompose from the heat and ultraviolet radiation of an arc. Because of the chemical breakdown of vapor-degreasing materials under ultraviolet radiation, arc welding should not be done in the vicinity of a vapor-degreasing operation. Carbon-arc welding, gas tungsten-arc welding and gas metal arc welding should be especially avoided in such areas, because they emit more ultraviolet radiation than other processes. Also, keep in mind that ozone and nitrogen oxides are formed when UV radiation passes through the air. These gases cause headaches, chest pains, irritation of the eyes, and an itchiness in the nose and throat.

There is one easy way to **reduce the risk** of exposure to hazardous fumes and gases: **keep your head out of the fume plume!** As obvious as this sounds, the failure to follow this advice is a common cause of fume and gas overexposure because the concentration of fume and gases is greatest in the plume. Keep fumes and gases from your breathing zone and general area using natural ventilation, mechanical ventilation, fixed or moveable exhaust hoods or local exhaust at the arc. Finally, it may be necessary to wear an approved respirator if adequate ventilation cannot be provided (see Ventilation section).

As a rule of thumb, for many mild steel electrode, if the air is visibly clear and you are comfortable, then the ventilation is generally adequate for your work. The most accurate way to determine if the worker exposure does not exceed the applicable exposure limit for compounds in the fumes and gases is to have an industrial hygienist take and analyze a sample of the air you are breathing. This is particularly important if you are welding with stainless, hardfacing or Special Ventilation products. All Lincoln MSDS have a maximum fume guideline number. If exposure to total fume is kept below that number, exposure to all fume from the electrode (not coatings or plating on the work) will be below the TLV.

There are also steps that you can take to identify hazardous substances in your welding environment. First, read the product label and material safety data sheet for the electrode posted in the work place or in the electrode or flux container to see what fumes can be reasonably expected from use of the product and to determine if special ventilation is needed. Secondly, know what the base metal is, and determine if there is any paint, plating, or coating that could expose you to toxic fumes and/or gases. Remove it from the metal being welded, if possible. If you start to feel uncomfortable, dizzy or nauseous, there is a possibility that you are being overexposed to fumes and gases, or suffering from oxygen deficiency. Stop welding and get some **fresh air** immediately. Notify your supervisor and co-workers so the situation can be corrected and other workers can avoid the hazard. Be sure you are following these safe practices, the consumable labeling and MSDS and improve the ventilation in your area. Do not continue welding until the situation has been corrected.

NOTE: The MSDS for all Lincoln consumables is available on Lincoln's website: www.lincolnelectric.com

Before we turn to the methods available to control welding fume exposure, you should understand a few basic terms:

Natural Ventilation is the movement of air through the workplace caused by natural forces. Outside, this is usually the wind. Inside, this may be the flow of air through open windows and doors.

Mechanical Ventilation is the movement of air through the workplace caused by an electrical device such as a portable fan or permanently mounted fan in the ceiling or wall.

Source Extraction (Local Exhaust) is a mechanical device used to capture welding fume at or near the arc and filter contaminants out of the air.

The ventilation or exhaust needed for your application depends upon many factors such as:

- workspace volume
- workspace configuration
- number of welders
- welding process and current
- consumables used (mild steel, hardfacing, stainless, etc.)
- allowable levels (TLV, PEL, etc.)
- material welded (including paint or plating)
- natural airflow

Your work area has **adequate ventilation** when there is enough ventilation and/or exhaust to control worker exposure to hazardous materials in the welding fumes and gases so the applicable limits for those materials is not exceeded. See Supplement 2 for the legal limits, the OSHA PEL (Permissible Exposure Limit), and the recommended guideline, the ACGIH TLV (Threshold Limit Value), for many compounds found in welding fume.



Ventilation

There are many methods which can be selected by the user to provide adequate ventilation for the specific application. The following section provides general information which may be helpful in evaluating what type of ventilation equipment may be suitable for your application. When ventilation equipment is installed, you should confirm worker exposure is controlled within applicable OSHA PEL and/or ACGIH TLV. According to OSHA regulations, when welding and cutting (mild steels), natural ventilation is usually considered sufficient to meet requirements, provided that:

1. The room or welding area contains at least 10,000 cubic feet (about 22' x 22' x 22') for each welder.
2. The ceiling height is not less than 16 feet.
3. Cross ventilation is not blocked by partitions, equipment, or other structural barriers.
4. Welding is not done in a confined space.

Spaces that do not meet these requirements should be equipped with mechanical ventilating equipment that exhausts at least 2000 cfm of air for each welder, except where local exhaust hoods or booths, or air-line respirators are used.

Important Safety Note:

When welding with electrodes which require special ventilation such as stainless or hardfacing (see instructions on container or MSDS) or on lead or cadmium plated steel and other metals or coatings which produce hazardous fumes, keep exposure as low as possible and below exposure limit values (PEL and TLV) for materials in the fume using local exhaust or mechanical ventilation. In confined spaces or in some circumstances, for example outdoors, a respirator may be required if exposure cannot be controlled to the PEL or TLV. (See MSDS and Supplement 3 of this brochure.) Additional precautions are also required when welding on galvanized steel.

Source Extraction Equipment

Mechanical ventilation is an effective method of fume control for many welding processes. Because it captures fume near the arc or source of the fume, which is more efficient in most cases, local exhaust, also called "source extraction", is a very effective means to control welding fume.

Source extraction of welding fumes can be provided by mobile or stationary, single or multi-station, exhaust and/or filtration equipment designed with adjustable fume extraction arms nozzles or guns, by fixed enclosures, booths or tables with extraction canopies also known as down-draft, or by back-draft or cross-draft tables/booths. Source extraction of weld fume falls into two categories: low vacuum/high volume, or high vacuum/low volume.

Low Vacuum/High Volume

Mobile or stationary, single or multi-station, large centralized exhaust and/or filtration equipment designed with adjustable fume extraction arms are usually low vacuum/high volume systems. When correctly positioned, the capture rate of adjustable fume extraction arms is suitable for all position welding and cutting. For more difficult to reach work areas, flexible hose may be used in place of adjustable fume extraction arms.

These arms generally move between 560 and 860 cubic feet per minute (CFM) (900 – 1400 m³/hr) of air, but use low vacuum levels (3 to 5 inches water gauge [750 – 1250 Pa]) to minimize power requirements. Water gauge (WG) is a measure of negative pressure: higher numbers mean more negative pressure (more "suction"). With this volume of airflow, the end of the arm can be placed 6 to 15 inches (160 – 375 mm) away from the arc and still effectively capture weld fume.

Fume extraction arms generally use a 6 or 8 inch diameter hose, or hose and tubing combinations. Arm lengths are typically 7, 10, or 13 feet (2, 3, or 4 m), with boom extensions available. The arms may be wall mounted, attached to mobile units, or incorporated into a centralized system.

In general, the farther the extraction hose is from the arc, the more volume of air movement is required to effectively capture welding fume. Overhead hoods (canopies), for example, capture most of the fume, but care must be taken to be sure fume is not pulled through the breathing zone of the operator.

Fixed enclosures, booths or tables with extraction canopies also known as **down-draft, back-draft or cross-draft booths/tables** are a variation of overhead hood technology and can be used as source extraction equipment. A booth is a fixed enclosure that consists of a top and at least two sides that surround the welding operation. These systems use a plenum with openings to the side, back or bottom of the work space rather than above it to capture the weld fume. The weld fume is extracted through the plenum and away from the breathing zone of the operator that is welding or cutting. Down-draft or back-draft booths/tables can be mobile or stationary, single or multi-station, exhaust and/or filtration systems. They are particularly suitable for in-position bench welding or cutting jobs and can be effective when small parts are being welded. The airflow required for effectiveness varies depending upon the installation design, but may be 1,000 CFM or higher.

There are advantages and limitations associated with low vacuum/high volume source extraction systems.



Mobiflex™ 200-M low vacuum mobile fume extraction unit.

Advantages

Limitations

Source extraction with large volume of air being extracted from welder breathing zone.	If not using filtration unit, exhausting air to outside requires make-up air systems and make-up heaters (ie. large volumes of displaced air need to be replaced, resulting in increased utility costs).
Auto-stop delay assists with removal of residual fumes.	Welder must stop to reposition arm over weld area(s).
Low noise level.	Filtration systems larger due to volume of air flow.
Flexible arm for repositioning.	Depending on design, ductwork can be large.
Low installation costs (ductwork).	
Low energy consumption (small fan unit with low rpm).	
Adjustable arms suitable for all-position welding.	

High Vacuum/Low Volume

High vacuum/low volume fume extraction systems are designed for close proximity (2 to 4 inches) positioning. High vacuum/low volume weld fume extraction is achieved with lower airflow rates than those encountered when utilizing low vacuum/high volume systems. There are two methods of high vacuum extraction: welding guns with built-in extraction (fume extraction guns), or separate suction nozzles of various designs.

Fume extraction guns use fume capture nozzles built into the gun tube and handle. The extraction airflow is approximately 35 to 60 CFM (60 – 100 m³/hr) for integrated fume extraction guns. Therefore, no repositioning is required, since the suction automatically follows the arc. The vacuum level is high (40 to 70 inches WG [9.96 X 10³ to 1.74 X 10⁴ Pascal]) permitting the use of hose featuring longer lengths (10 to 25 feet) and smaller diameters (1.25 to 1.75 inches). Fume extraction gun designs have been improved to be more ergonomic and user friendly. Depending upon the type of welding, particularly "in position" welding, extraction guns may be a good solution.

Suction nozzles are positioned near the weld, and commonly use capture distances of less than four inches. Depending upon the design, airflow of suction nozzles is typically between 80 to 100 CFM (135 – 170 m³/hr). Suction nozzles must be kept near the arc to be used effectively.

The capture rate for fume extraction guns or nozzles is highest when used in flat and horizontal welding positions. High vacuum equipment ranges from small, portable, mobile units to stationary, single or multi-station, large centralized filtration systems.

There are advantages and limitations associated with high vacuum/low volume source extraction systems.

Advantages	Limitations
When using a fume extraction gun, welder does not need to stop and reposition extraction device.	Required when using a suction nozzle. Welder may need to stop to reposition extraction device.
Low volume of air is displaced- results in energy efficiency and conservation.	High noise level due to increased air velocity and high motor rpm of the fan unit.
Ductwork smaller in diameter (3 to 10 inches) vs. low vacuum systems.	Possible removal of shielding gases affecting weld integrity if nozzle or gun placed too close to source.
Low obstruction of welder vision.	Greater energy consumption (large fan unit with high rpm).
Suitable for heavier particulate (ie. grinding dust).	Residual fumes not extracted.
Suitable option for confined, difficult to reach work spaces.	Less effective in out-of-position welding.
Smaller filter systems due to less volume of airflow.	

Fume extraction is only one component in reducing welding fume. Users should also consider the selection of the welding process, welding procedure, or consumable. Many times a combination of fume extraction, training, process change, and/or consumable change is needed to reduce the amount of fume to acceptable levels. Solutions to a particular application may involve one or all of these factors and the user must determine which solution best fits their application.

OSHA regulations include specific requirements for exhaust systems which should be reviewed when selecting fume extraction systems (see Supplement 2).



Miniflex™ high vacuum portable fume extraction unit.

Exhaust vs. Filtration

Source extraction exhaust equipment captures and extracts weld fumes from the source and exhausts the fumes to the outside atmosphere. This technique removes welding fume from the breathing zone of the welder but can also displace large volumes of conditioned air which may lead to increased utility and heating costs.

Source extraction filtration equipment captures and extracts weld fumes from the source and filters the fumes by passing them through a cellulose and/or polyester filter cartridge or electrostatic filter. Depending on the weld application, environment, federal or local regulations, and filtration efficiency levels, filtered air may be re-circulated back into the facility or exhausted to the outside atmosphere. By re-circulating filtered air back into the work environment compared to exhausting to the outside, source extraction filtration equipment can be more economical to operate. Particularly in winter months, substantially lower heating costs may be recognized, as less replacement air is required with filtration versus exhaust systems.

Using a cellulose or polyester filter cartridge or electrostatic filter will depend upon the weld application. Electrostatic filters may also be used however, they lose efficiency if they are not frequently washed.

Regardless of the type of mechanical ventilation (exhaust or filtration) source extraction system used, the important factor is that it is a tool designed to control exposure to welding fume and its constituents. All forms of mechanical ventilation or source extraction equipment require routine maintenance. In addition, when using weld fume source extraction equipment, sparks from welding, cutting or grinding processes can cause fire within the equipment. To control this potential fire hazard, operation, service and maintenance instructions for source extraction equipment should be followed.

Note:

It is the equipment owner and operator's responsibility to comply with Occupational Safety, Health Administration (OSHA) Permissible Exposure Limits (PELs) or American Conference of Governments Industrial Hygienists (ACGIH) TLVs for welding fume. It is the responsibility of the equipment owner to research, test and comply with regulations which may apply to filtered air recirculated inside the facility or unfiltered air is exhausted outside of the facility.

Working in Confined Spaces

When arc welding in a confined area, such as a boiler, tank, or the hold of a ship, bear in mind that all the hazards associated with normal arc welding are amplified, so the precautions mentioned here are even more important. This subject is very complicated and only basic precautions related to arc welding will be discussed in this brochure. Per OSHA document 29 CFR 1910.146, a particular area is considered a confined space if it:

- 1) Is large enough and so configured that an employee can bodily enter and perform assigned work; and
- 2) Has limited or restricted means for entry or exit (for example, tanks, vessels, silos, storage bins, hoppers, vaults, and pits are spaces that may have limited means of entry.); and
- 3) Is not designed for continuous employee occupancy.

There is a greater danger that enough **flammable gases** may be present in the confined space to cause an explosion. The metal of the enclosure can become part of the welding circuit, so any metal you touch (the walls, floor, ceiling) is **electrically "hot"**. Welding fumes can accumulate more rapidly, with a higher concentration; gases can force out the **breathable air**, suffocating you in the process.

Per OSHA document 29 CFR 1910.146(d)(5)(iii); after an area has been deemed a confined space, the existence of the following atmospheric hazards are to be determined:

- 1) Test for oxygen
- 2) Test for combustible gases and vapors
- 3) Test for toxic gases and vapors

The workplace and OSHA rules regarding confined spaces must be followed. Make sure that your body is insulated from the work-piece using dry insulation. Wear dry gloves and only use a well-insulated electrode holder. Semiautomatic constant voltage welders with cold electrode or stick welders equipped with a device to lower the no-load voltage are recommended, especially when the work area is wet. Make sure that there is adequate ventilation and exhaust (a respirator or an air-supplied respirator may be necessary depending on the application), and that there are no flammable coatings, liquids or gases nearby.

Lastly, you must have someone outside the enclosure trained to handle emergencies, with rescue procedures and a means to disconnect power to your equipment and pull you out if danger arises. We cannot stress this strongly enough: however experienced you are, do not attempt work of this nature without constant communication with the person outside the confined area. When welding within a confined area, problems which arise can immediately become very serious and, in some cases, life-threatening. It is for that reason that OSHA regulations and workplace procedures for confined space work must be followed.

GUIDE FOR SHADE NUMBERS

OPERATION	ELECTRODE SIZE 1/32 in. (mm)	ARC CURRENT (A)	MINIMUM PROTECTIVE SHADE	SUGGESTED(1) SHADE NO. (COMFORT)
Shielded metal arc welding	Less than 3 (2.5)	Less than 60	7	–
	3-5 (2.5–4)	60-160	8	10
	5-8 (4–6.4)	160-250	10	12
	More than 8 (6.4)	250-550	11	14
Gas metal arc welding and flux cored arc welding		Less than 60	7	–
		60-160	10	11
		160-250	10	12
		250-500	10	14
Gas tungsten arc welding		Less than 50	8	10
		50-150	8	12
		150-500	10	14
Air carbon Arc cutting	(Light)	Less than 500	10	12
	(Heavy)	500-1000	11	14
Plasma arc welding		Less than 20	6	6 to 8
		20-100	8	10
		100-400	10	12
		400-800	11	14
Plasma arc cutting	(Light) ⁽²⁾	Less than 300	8	9
	(Medium) ⁽²⁾	300-400	9	12
	(Heavy) ⁽²⁾	400-800	10	14
Torch brazing		–	–	3 or 4
Torch soldering		–	–	2
Carbon arc welding		–	–	14
PLATE THICKNESS				
	in.	mm		
Gas welding Light Medium Heavy	Under 1/8	Under 3.2		4 or 5
	1/8 to 1/2	3.2 to 12.7		5 or 6
	Over 1/2	Over 12.7		6 or 8
Oxygen cutting Light Medium Heavy	Under 1	Under 25		3 or 4
	1 to 6	25 to 150		4 or 5
	Over 6	Over 150		5 or 6

⁽¹⁾ As a rule of thumb, start with a shade that is too dark, then go to a lighter shade which gives sufficient view of the weld zone without going below the minimum. In oxyfuel gas welding or cutting where the torch produces a high yellow light, it is desirable to use a filter lens that absorbs the yellow or sodium line the visible light of the (spectrum) operation

⁽²⁾ These values apply where the actual arc is clearly seen. Experience has shown that lighter filters may be used when the arc is hidden by the workpiece.

Data from ANSI Z49.1-2005

BIBLIOGRAPHY AND SUGGESTED READING

ANSI Z87.1, *Practice for Occupational and Educational Eye and Face Protection*, American National Standards Institute, 11 West 42nd Street, New York, NY 10036.

Arc Welding and Your Health: A Handbook of Health Information for Welding. Published by The American Industrial Hygiene Association, 2700 Prosperity Avenue, Suite 250, Fairfax, VA 22031-4319.

NFPA Standard 51B, *Cutting and Welding Processes*, National Fire Protection Association, 1 Batterymarch Park, P.O. Box 9146, Quincy, MA 02269-9959.

OSHA General Industry Standard 29 CFR 1910 Subpart Q. OSHA Hazard Communication Standard 29 CFR 1910.1200. Available from the Occupational Safety and Health Administration at <http://www.osha.org> or contact your local OSHA office.

The following publications are published by The American Welding Society, P.O. Box 351040, Miami, Florida 33135. AWS publications may be purchased from the American Welding society at <http://www.aws.org> or by contacting the AWS at 800-443-9353.

ANSI, Standard Z49.1, *Safety in Welding, Cutting and Allied Processes*. Z49.1 is now available for download at no charge at <http://www.lincolnelectric.com/community/safety/> or at the AWS website <http://www.aws.org>.

AWS F1.1, *Method for Sampling Airborne Particulates Generated by Welding and Allied Processes*.

AWS F1.2, *Laboratory Method for Measuring Fume Generation Rates and Total Fume Emission of Welding and Allied Processes*.

AWS F1.3, *Evaluating Contaminants in the Welding Environment: A Strategic Sampling Guide*.

AWS F1.5, *Methods for Sampling and Analyzing Gases from Welding and Allied Processes*.

AWS F3.2, *Ventilation Guide for Welding Fume Control*

AWS F4.1, *Recommended Safe Practices for the Preparation for Welding and Cutting of Containers and Piping That Have Held Hazardous Substances*.

AWS SHF, *Safety and Health Facts Sheets*. Available free of charge from the AWS website at <http://www.aws.org>.

LISTED BELOW ARE SOME TYPICAL INGREDIENTS IN WELDING ELECTRODES AND THEIR TLV (ACGIH) GUIDELINES AND PEL (OSHA) EXPOSURE LIMITS

INGREDIENTS	CAS No.	TLV mg/m ³	PEL mg/m ³
Aluminum and/or aluminum alloys (as Al)*****	7429-90-5	10	15
Aluminum oxide and/or Bauxite*****	1344-28-1	10	5**
Barium compounds (as Ba)*****	513-77-9	****	****
Chromium and chromium alloys or compounds (as Cr)*****	7440-47-3	0.5(b)	.005(b)
Fluorides (as F)	7789-75-5	2.5	2.5
Iron	7439-89-6	10*	10*
Limestone and/or calcium carbonate	1317-65-3	10	15
Lithium compounds (as Li)	554-13-2	10*	10*
Magnesite	1309-48-4	10	15
Magnesium and/or magnesium alloys and compounds (as Mg)	7439-95-4	10*	10*
Manganese and/or manganese alloys and compounds (as Mn)*****	7439-96-5	0.2	5.0(c)
Mineral silicates	1332-58-7	5**	5**
Molybdenum alloys (as Mo)	7439-98-7	10	10
Nickel*****	7440-02-0	1.5	1
Silicates and other binders	1344-09-8	10*	10*
Silicon and/or silicon alloys and compounds (as Si)	7440-21-3	10*	10*
Strontium compounds (as Sr)	1633-05-2	10*	10*
Zirconium alloys and compounds (as Zr)	12004-83-0	5	5

Supplemental Information:

- (*) Not listed. Nuisance value maximum is 10 milligrams per cubic meter. PEL value for iron oxide is 10 milligrams per cubic meter. TLV value for iron oxide is 5 milligrams per cubic meter.
- (**) As respirable dust.
- (*****) Subject to the reporting requirements of Sections 311, 312, and 313 of the Emergency Planning and Community Right-to-Know Act of 1986 and of 40CFR 370 and 372.
- (b) The PEL for chromium (VI) is .005 milligrams per cubic meter as an 8 hour time weighted average. The TLV for water-soluble chromium (VI) is 0.05 milligrams per cubic meter. The TLV for insoluble chromium (VI) is 0.01 milligrams per cubic meter.
- (c) Values are for manganese fume. STEL (Short Term Exposure Limit) is 3.0 milligrams per cubic meter. OSHA PEL is a ceiling value.
- (****) There is no listed value for insoluble barium compounds. The TLV for soluble barium compounds is 0.5 mg/m³.

TLV and PEL values are as of April 2006. Always check Material Safety Data Sheet (MSDS) with product or on the Lincoln Electric website at <http://www.lincolnelectric.com>

⚠ WARNING

⚠ CALIFORNIA PROPOSITION 65 WARNINGS ⚠

Diesel engine exhaust and some of its constituents are known to the State of California to cause cancer, birth defects, and other reproductive harm.

The Above For Diesel Engines

The engine exhaust from this product contains chemicals known to the State of California to cause cancer, birth defects, or other reproductive harm.

The Above For Gasoline Engines

ARC WELDING CAN BE HAZARDOUS. PROTECT YOURSELF AND OTHERS FROM POSSIBLE SERIOUS INJURY OR DEATH. KEEP CHILDREN AWAY. PACEMAKER WEARERS SHOULD CONSULT WITH THEIR DOCTOR BEFORE OPERATING.

Read and understand the following safety highlights. For additional safety information, it is strongly recommended that you purchase a copy of "Safety in Welding & Cutting - ANSI Standard Z49.1" from the American Welding Society, P.O. Box 351040, Miami, Florida 33135 or CSA Standard W117.2-1974. A Free copy of "Arc Welding Safety" booklet E205 is available from the Lincoln Electric Company, 22801 St. Clair Avenue, Cleveland, Ohio 44117-1199.

BE SURE THAT ALL INSTALLATION, OPERATION, MAINTENANCE AND REPAIR PROCEDURES ARE PERFORMED ONLY BY QUALIFIED INDIVIDUALS.



FOR ENGINE powered equipment.

1.a. Turn the engine off before troubleshooting and maintenance work unless the maintenance work requires it to be running.



1.b. Operate engines in open, well-ventilated areas or vent the engine exhaust fumes outdoors.



1.c. Do not add the fuel near an open flame welding arc or when the engine is running. Stop the engine and allow it to cool before refueling to prevent spilled fuel from vaporizing on contact with hot engine parts and igniting. Do not spill fuel when filling tank. If fuel is spilled, wipe it up and do not start engine until fumes have been eliminated.

1.d. Keep all equipment safety guards, covers and devices in position and in good repair. Keep hands, hair, clothing and tools away from V-belts, gears, fans and all other moving parts when starting, operating or repairing equipment.

1.e. In some cases it may be necessary to remove safety guards to perform required maintenance. Remove guards only when necessary and replace them when the maintenance requiring their removal is complete. Always use the greatest care when working near moving parts.



1.f. Do not put your hands near the engine fan. Do not attempt to override the governor or idler by pushing on the throttle control rods while the engine is running.

1.g. To prevent accidentally starting gasoline engines while turning the engine or welding generator during maintenance work, disconnect the spark plug wires, distributor cap or magneto wire as appropriate.



1.h. To avoid scalding, do not remove the radiator pressure cap when the engine is hot.



ELECTRIC AND MAGNETIC FIELDS may be dangerous

2.a. Electric current flowing through any conductor causes localized Electric and Magnetic Fields (EMF). Welding current creates EMF fields around welding cables and welding machines

2.b. EMF fields may interfere with some pacemakers, and welders having a pacemaker should consult their physician before welding.

2.c. Exposure to EMF fields in welding may have other health effects which are now not known.

2.d. All welders should use the following procedures in order to minimize exposure to EMF fields from the welding circuit:

2.d.1. Route the electrode and work cables together - Secure them with tape when possible.

2.d.2. Never coil the electrode lead around your body.

2.d.3. Do not place your body between the electrode and work cables. If the electrode cable is on your right side, the work cable should also be on your right side.

2.d.4. Connect the work cable to the workpiece as close as possible to the area being welded.

2.d.5. Do not work next to welding power source.



ELECTRIC SHOCK can kill.

- 3.a. The electrode and work (or ground) circuits are electrically “hot” when the welder is on. Do not touch these “hot” parts with your bare skin or wet clothing. Wear dry, hole-free gloves to insulate hands.
- 3.b. Insulate yourself from work and ground using dry insulation. Make certain the insulation is large enough to cover your full area of physical contact with work and ground.

In addition to the normal safety precautions, if welding must be performed under electrically hazardous conditions (in damp locations or while wearing wet clothing; on metal structures such as floors, gratings or scaffolds; when in cramped positions such as sitting, kneeling or lying, if there is a high risk of unavoidable or accidental contact with the workpiece or ground) use the following equipment:

- **Semiautomatic DC Constant Voltage (Wire) Welder.**
 - **DC Manual (Stick) Welder.**
 - **AC Welder with Reduced Voltage Control.**
- 3.c. In semiautomatic or automatic wire welding, the electrode, electrode reel, welding head, nozzle or semiautomatic welding gun are also electrically “hot”.
- 3.d. Always be sure the work cable makes a good electrical connection with the metal being welded. The connection should be as close as possible to the area being welded.
- 3.e. Ground the work or metal to be welded to a good electrical (earth) ground.
- 3.f. Maintain the electrode holder, work clamp, welding cable and welding machine in good, safe operating condition. Replace damaged insulation.
- 3.g. Never dip the electrode in water for cooling.
- 3.h. Never simultaneously touch electrically “hot” parts of electrode holders connected to two welders because voltage between the two can be the total of the open circuit voltage of both welders.
- 3.i. When working above floor level, use a safety belt to protect yourself from a fall should you get a shock.
- 3.j. Also see Items 6.c. and 8.



ARC RAYS can burn.

- 4.a. Use a shield with the proper filter and cover plates to protect your eyes from sparks and the rays of the arc when welding or observing open arc welding. Headshield and filter lens should conform to ANSI Z87.1 standards.
- 4.b. Use suitable clothing made from durable flame-resistant material to protect your skin and that of your helpers from the arc rays.
- 4.c. Protect other nearby personnel with suitable, non-flammable screening and/or warn them not to watch the arc nor expose themselves to the arc rays or to hot spatter or metal.



FUMES AND GASES can be dangerous.

- 5.a. Welding may produce fumes and gases hazardous to health. Avoid breathing these fumes and gases. When welding, keep your head out of the fume. Use enough ventilation and/or exhaust at the arc to keep fumes and gases away from the breathing zone. **When welding with electrodes which require special ventilation such as stainless or hard facing (see instructions on container or MSDS) or on lead or cadmium plated steel and other metals or coatings which produce highly toxic fumes, keep exposure as low as possible and below Threshold Limit Values (TLV) using local exhaust or mechanical ventilation. In confined spaces or in some circumstances, outdoors, a respirator may be required. Additional precautions are also required when welding on galvanized steel.**
5. b. The operation of welding fume control equipment is affected by various factors including proper use and positioning of the equipment, maintenance of the equipment and the specific welding procedure and application involved. Worker exposure level should be checked upon installation and periodically thereafter to be certain it is within applicable OSHA PEL and ACGIH TLV limits.
- 5.c. Do not weld in locations near chlorinated hydrocarbon vapors coming from degreasing, cleaning or spraying operations. The heat and rays of the arc can react with solvent vapors to form phosgene, a highly toxic gas, and other irritating products.
- 5.d. Shielding gases used for arc welding can displace air and cause injury or death. Always use enough ventilation, especially in confined areas, to insure breathing air is safe.
- 5.e. Read and understand the manufacturer’s instructions for this equipment and the consumables to be used, including the material safety data sheet (MSDS) and follow your employer’s safety practices. MSDS forms are available from your welding distributor or from the manufacturer.
- 5.f. Also see item 1.b.

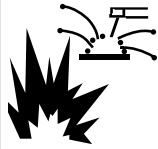

WELDING and CUTTING SPARKS can cause fire or explosion.

6.a. Remove fire hazards from the welding area. If this is not possible, cover them to prevent the welding sparks from starting a fire.

Remember that welding sparks and hot materials from welding can easily go through small cracks and openings to adjacent areas. Avoid welding near hydraulic lines. Have a fire extinguisher readily available.

- 6.b. Where compressed gases are to be used at the job site, special precautions should be used to prevent hazardous situations. Refer to "Safety in Welding and Cutting" (ANSI Standard Z49.1) and the operating information for the equipment being used.
- 6.c. When not welding, make certain no part of the electrode circuit is touching the work or ground. Accidental contact can cause overheating and create a fire hazard.
- 6.d. Do not heat, cut or weld tanks, drums or containers until the proper steps have been taken to insure that such procedures will not cause flammable or toxic vapors from substances inside. They can cause an explosion even though they have been "cleaned". For information, purchase "Recommended Safe Practices for the Preparation for Welding and Cutting of Containers and Piping That Have Held Hazardous Substances", AWS F4.1 from the American Welding Society (see address above).
- 6.e. Vent hollow castings or containers before heating, cutting or welding. They may explode.
- 6.f. Sparks and spatter are thrown from the welding arc. Wear oil free protective garments such as leather gloves, heavy shirt, cuffless trousers, high shoes and a cap over your hair. Wear ear plugs when welding out of position or in confined places. Always wear safety glasses with side shields when in a welding area.
- 6.g. Connect the work cable to the work as close to the welding area as practical. Work cables connected to the building framework or other locations away from the welding area increase the possibility of the welding current passing through lifting chains, crane cables or other alternate circuits. This can create fire hazards or overheat lifting chains or cables until they fail.
- 6.h. Also see item 1.c.
- 6.i. Read and follow NFPA 51B "Standard for Fire Prevention During Welding, Cutting and Other Hot Work", available from NFPA, 1 Batterymarch Park, PO box 9101, Quincy, Ma 022690-9101.
- 6.j. Do not use a welding power source for pipe thawing.



CYLINDER may explode if damaged.

7.a. Use only compressed gas cylinders containing the correct shielding gas for the process used and properly operating regulators designed for the gas and pressure used. All hoses, fittings, etc. should be suitable for the application and maintained in good condition.

- 7.b. Always keep cylinders in an upright position securely chained to an undercarriage or fixed support.
- 7.c. Cylinders should be located:
- Away from areas where they may be struck or subjected to physical damage.
 - A safe distance from arc welding or cutting operations and any other source of heat, sparks, or flame.
- 7.d. Never allow the electrode, electrode holder or any other electrically "hot" parts to touch a cylinder.
- 7.e. Keep your head and face away from the cylinder valve outlet when opening the cylinder valve.
- 7.f. Valve protection caps should always be in place and hand tight except when the cylinder is in use or connected for use.
- 7.g. Read and follow the instructions on compressed gas cylinders, associated equipment, and CGA publication P-1, "Precautions for Safe Handling of Compressed Gases in Cylinders," available from the Compressed Gas Association 1235 Jefferson Davis Highway, Arlington, VA 22202.



FOR ELECTRICALLY powered equipment.

- 8.a. Turn off input power using the disconnect switch at the fuse box before working on the equipment.
- 8.b. Install equipment in accordance with the U.S. National Electrical Code, all local codes and the manufacturer's recommendations.
- 8.c. Ground the equipment in accordance with the U.S. National Electrical Code and the manufacturer's recommendations.

PRÉCAUTIONS DE SÛRETÉ

Pour votre propre protection lire et observer toutes les instructions et les précautions de sûreté spécifiques qui paraissent dans ce manuel aussi bien que les précautions de sûreté générales suivantes:

Sûreté Pour Soudage A L'Arc

1. Protégez-vous contre la secousse électrique:
 - a. Les circuits à l'électrode et à la pièce sont sous tension quand la machine à souder est en marche. Eviter toujours tout contact entre les parties sous tension et la peau nue ou les vêtements mouillés. Porter des gants secs et sans trous pour isoler les mains.
 - b. Faire très attention de bien s'isoler de la masse quand on soude dans des endroits humides, ou sur un plancher métallique ou des grilles métalliques, principalement dans les positions assis ou couché pour lesquelles une grande partie du corps peut être en contact avec la masse.
 - c. Maintenir le porte-électrode, la pince de masse, le câble de soudage et la machine à souder en bon et sûr état de fonctionnement.
 - d. Ne jamais plonger le porte-électrode dans l'eau pour le refroidir.
 - e. Ne jamais toucher simultanément les parties sous tension des porte-électrodes connectés à deux machines à souder parce que la tension entre les deux pinces peut être le total de la tension à vide des deux machines.
 - f. Si on utilise la machine à souder comme une source de courant pour soudage semi-automatique, ces précautions pour le porte-électrode s'appliquent aussi au pistolet de soudage.
2. Dans le cas de travail au dessus du niveau du sol, se protéger contre les chutes dans le cas où on recoit un choc. Ne jamais enrouler le câble-électrode autour de n'importe quelle partie du corps.
3. Un coup d'arc peut être plus sévère qu'un coup de soliel, donc:
 - a. Utiliser un bon masque avec un verre filtrant approprié ainsi qu'un verre blanc afin de se protéger les yeux du rayonnement de l'arc et des projections quand on soude ou quand on regarde l'arc.
 - b. Porter des vêtements convenables afin de protéger la peau de soudeur et des aides contre le rayonnement de l'arc.
 - c. Protéger l'autre personnel travaillant à proximité au soudage à l'aide d'écrans appropriés et non-inflammables.
4. Des gouttes de laitier en fusion sont émises de l'arc de soudage. Se protéger avec des vêtements de protection libres de l'huile, tels que les gants en cuir, chemise épaisse, pantalons sans revers, et chaussures montantes.







5. Toujours porter des lunettes de sécurité dans la zone de soudage. Utiliser des lunettes avec écrans latéraux dans les zones où l'on pique le laitier.
6. Eloigner les matériaux inflammables ou les recouvrir afin de prévenir tout risque d'incendie dû aux étincelles.
7. Quand on ne soude pas, poser la pince à un endroit isolé de la masse. Un court-circuit accidentel peut provoquer un échauffement et un risque d'incendie.
8. S'assurer que la masse est connectée le plus près possible de la zone de travail qu'il est pratique de le faire. Si on place la masse sur la charpente de la construction ou d'autres endroits éloignés de la zone de travail, on augmente le risque de voir passer le courant de soudage par les chaînes de levage, câbles de grue, ou autres circuits. Cela peut provoquer des risques d'incendie ou d'échauffement des chaînes et des câbles jusqu'à ce qu'ils se rompent.
9. Assurer une ventilation suffisante dans la zone de soudage. Ceci est particulièrement important pour le soudage de tôles galvanisées plombées, ou cadmiées ou tout autre métal qui produit des fumeés toxiques.
10. Ne pas souder en présence de vapeurs de chlore provenant d'opérations de dégraissage, nettoyage ou pistolage. La chaleur ou les rayons de l'arc peuvent réagir avec les vapeurs du solvant pour produire du phosgène (gas fortement toxique) ou autres produits irritants.
11. Pour obtenir de plus amples renseignements sur la sûreté, voir le code "Code for safety in welding and cutting" CSA Standard W 117.2-1974.

PRÉCAUTIONS DE SÛRETÉ POUR LES MACHINES À SOUDER À TRANSFORMATEUR ET À REDRESSEUR

1. Relier à la terre le chassis du poste conformément au code de l'électricité et aux recommandations du fabricant. Le dispositif de montage ou la pièce à souder doit être branché à une bonne mise à la terre.
2. Autant que possible, l'installation et l'entretien du poste seront effectués par un électricien qualifié.
3. Avant de faire des travaux à l'intérieur de poste, la débrancher à l'interrupteur à la boîte de fusibles.
4. Garder tous les couvercles et dispositifs de sûreté à leur place.

WARNING LABEL/OPERATING MANUAL REQUEST FORM

NOTE: S18494 WARNING LABELS, SUCH AS THE ONE BELOW FOR LINCOLN ELECTRIC WELDERS, ARE AVAILABLE FREE OF CHARGE to update your welding equipment. Operating manuals are also available upon request. PLEASE write to The Lincoln Electric Company, 22801 St. Clair Ave., Cleveland, Ohio 44117-1199 or visit www.lincolnelectric.com and make the request online.

Read this Warning		⚠ WARNING	Protect yourself and others.	
	ELECTRIC SHOCK can kill.		ARC RAYS can burn.	
	<ul style="list-style-type: none"> Do not touch electrically live parts or electrode with skin or wet clothing. Insulate yourself from work and ground. 		<ul style="list-style-type: none"> Wear eye, ear and body protection. 	
	FUMES AND GASES can be dangerous.		HIGH VOLTAGE can kill.	
	<ul style="list-style-type: none"> Keep your head out of fumes. Use ventilation or exhaust to remove fumes from breathing zone. 		<ul style="list-style-type: none"> Do not operate with covers removed. Turn power off before servicing. Do not touch electrically live parts. 	
	WELDING SPARKS can cause fire or explosion.		MOVING PARTS can injure.	
	<ul style="list-style-type: none"> Keep flammable material away. 		<ul style="list-style-type: none"> Keep away from moving parts. Do not operate with panels off. 	
<p>READ AND UNDERSTAND THE MANUFACTURER'S INSTRUCTIONS FOR THIS EQUIPMENT AND THE CONSUMABLES TO BE USED, INCLUDING THE MATERIAL SAFETY DATA SHEET (MSDS) AND FOLLOW YOUR EMPLOYER'S SAFETY PRACTICES.</p> <p>See American National Standard Z49.1, "Safety in Welding and Cutting", published by the American Welding Society, 550 Le Jeune Rd., Miami, Florida 33126. OSHA Safety and Health Standards, 29 CFR 1910 available from U.S. Government Printing Office, Washington, D.C. 20402.</p> <p align="right">DO NOT REMOVE THIS WARNING</p>				





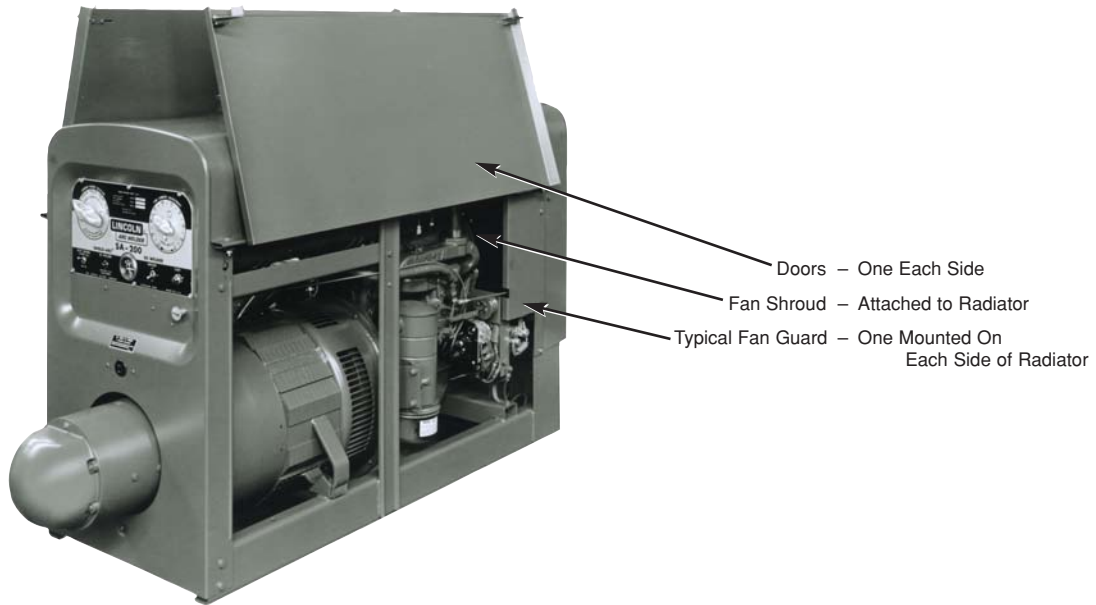

ENGINE WELDER FAN GUARDS

In order to determine whether your engine welder has the proper fan guards, compare your welder with the photo below. If your welder lacks the guards shown, contact your nearest Lincoln Field Service Shop or Distributor for assistance.

NOTE: On some engine welders, including the SA-200, the original fan guard design shown below has been modified to provide added protection and/or to make it more likely to be replaced after maintenance. Check with a Lincoln Field Service Shop or Distributor to determine if updated guarding is available for your welder.

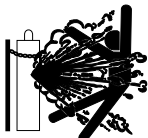

WELDING SAFETY CHECKLIST

HAZARD	FACTORS TO CONSIDER	PRECAUTION SUMMARY
<p>Electric shock can kill</p> 	<ul style="list-style-type: none"> • Wetness • Welder in or on workpiece • Confined space • Electrode holder and cable insulation 	<ul style="list-style-type: none"> • Insulate welder from workpiece and ground using <i>dry</i> insulation. Rubber mat or dry wood. • Wear <i>dry, hole-free</i> gloves. (Change as necessary to keep dry.) • Do not touch electrically “hot” parts or electrode with bare skin or wet clothing. • If wet area and welder cannot be insulated from workpiece with dry insulation, use a semiautomatic, constant-voltage welder or stick welder with voltage reducing device. • Keep electrode holder and cable insulation in good condition. Do not use if insulation damaged or missing.
<p>Fumes and gases can be dangerous</p> 	<ul style="list-style-type: none"> • Confined area • Positioning of welder’s head • Lack of general ventilation • Electrode types, i.e., manganese, chromium, etc. See MSDS • Base metal coatings, galvanize, paint 	<ul style="list-style-type: none"> • Use ventilation or exhaust to keep air breathing zone clear, comfortable. • Use helmet and positioning of head to minimize fume in breathing zone. • Read warnings on electrode container and material safety data sheet (MSDS) for electrode. • Provide additional ventilation/exhaust where special ventilation requirements exist. • Use special care when welding in a confined area. • Do not weld unless ventilation is adequate.
<p>Welding sparks can cause fire or explosion</p> 	<ul style="list-style-type: none"> • Containers which have held combustibles • Flammable materials 	<ul style="list-style-type: none"> • Do not weld on containers which have held combustible materials (unless strict AWS F4.1 procedures are followed). Check before welding. • Remove flammable materials from welding area or shield from sparks, heat. • Keep a fire watch in area during and after welding. • Keep a fire extinguisher in the welding area. • Wear fire retardant clothing and hat. Use earplugs when welding overhead.
<p>Arc rays can burn eyes and skin</p> 	<ul style="list-style-type: none"> • Process: gas-shielded arc most severe 	<ul style="list-style-type: none"> • Select a filter lens which is comfortable for you while welding. • Always use helmet when welding. • Provide non-flammable shielding to protect others. • Wear clothing which protects skin while welding.
<p>Confined space</p> 	<ul style="list-style-type: none"> • Metal enclosure • Wetness • Restricted entry • Heavier than air gas • Welder inside or on workpiece 	<ul style="list-style-type: none"> • Carefully evaluate adequacy of ventilation especially where electrode requires special ventilation or where gas may displace breathing air. • If basic electric shock precautions cannot be followed to insulate welder from work and electrode, use semiautomatic, constant-voltage equipment with cold electrode or stick welder with voltage reducing device. • Provide welder helper and method of welder retrieval from outside enclosure.
<p>General work area hazards</p>   	<ul style="list-style-type: none"> • Cluttered area • Indirect work (welding ground) connection • Electrical equipment • Engine-driven equipment • Gas cylinders 	<ul style="list-style-type: none"> • Keep cables, materials, tools neatly organized. • Connect work cable as close as possible to area where welding is being performed. Do <i>not</i> allow alternate circuits through scaffold cables, hoist chains, ground leads. • Use only double insulated or properly grounded equipment. • Always disconnect power to equipment before servicing. • Use in only open, well ventilated areas. • Keep enclosure complete and guards in place. • See Lincoln service shop if guards are missing. • Refuel with engine off. • If using auxiliary power, OSHA may require GFI protection or assured grounding program (or isolated windings if less than 5KW). • Never touch cylinder with the electrode. • Never lift a machine with cylinder attached. • Keep cylinder upright and chained to support.

District Sales Offices

U.S.A.

ALABAMA

BIRMINGHAM 35124-1156
(205) 988-8232
MOBILE 36582-5209
(251) 443-6524

ALASKA

Contact VANCOUVER, WA
(360) 693-4712

ARIZONA

PHOENIX 85260-1745
(480) 348-2004

ARKANSAS

LITTLE ROCK 72032-4371
(501) 764-0480

CALIFORNIA

FRESNO 93722-3949
(559) 276-0110
LOS ANGELES 90670-2936
(562) 906-7700
SAN DIEGO 92065-4165
(760) 787-1970
N. CALIFORNIA 95762-5706
(916) 939-8788

COLORADO

DENVER 80112-5115
(303) 792-2418

CONNECTICUT

NORTH HAVEN 06238-1090
(860) 742-8887

DELAWARE

Contact PHILADELPHIA, PA
(610) 543-9462

FLORIDA

JACKSONVILLE 32216-4634
(904) 642-3177
MIAMI 33178-1175
(305) 888-3203
ORLANDO 32714-1954
(407) 788-8557
TAMPA
(407) 788-8557

GEORGIA

ATLANTA 30122-3811
(888) 935-3860
SAVANNAH 31324-5180
(912) 656-1978

HAWAII

Contact LOS ANGELES, CA
(562) 906-7700

IDAHO

Contact SALT LAKE CITY, UT
(801) 233-9353

ILLINOIS

CHICAGO 60440-3538
(630) 783-3600
PEORIA 60527-5629
(630) 920-1500

INDIANA

FT. WAYNE 46825-5547
(260) 484-4422
INDIANAPOLIS 46250-5536
(317) 845-8445

IOWA

CEDAR RAPIDS 52402-3160
(319) 362-6804
DAVENPORT 52806-1344
(563) 386-6522
DES MOINES
(563) 386-6522

KANSAS

KANSAS CITY 66214-1629
(913) 894-0888
WICHITA 67037-9614
(316) 259-8842

KENTUCKY

LOUISVILLE 47112-7025
(502) 727-7335

LOUISIANA

BATON ROUGE 70808-3150
(225) 922-5151
LAFAYETTE 70507-3126
(337) 886-1090
SHREVEPORT 75692-9313
(318) 518-4099

MAINE

Contact BOSTON MA
(508) 788-9353

MARYLAND

BALTIMORE 21128-8936
(571) 283-2565

MASSACHUSETTS

BOSTON 01581-2658
(508) 788-9353

MICHIGAN

DETROIT 48393-4700
(248) 348-2575
FLINT 48439-8728
(810) 695-2627
GRAND RAPIDS 49512-3924
(616) 942-8780

MINNESOTA

MINNEAPOLIS 55369-5455
(763) 391-8384

MISSISSIPPI

JACKSON 39212-9635
(601) 372-7679

MISSOURI

KANSAS CITY (KS) 66214-1629
(913) 894-0888
ST. LOUIS 63045-1210
(314) 291-5877
SPRINGFIELD 65807-8699
(417) 841-2779

MONTANA

Contact VANCOUVER, WA
(360) 693-4712

NEBRASKA

OMAHA 68046-7031
(402) 203-6401

NEW HAMPSHIRE

Contact BOSTON MA
(508) 788-9353

NEW JERSEY

EDISON 08818-6433
(732) 225-2000

NEW MEXICO

ALBUQUERQUE 87120-5360
(505) 890-6347

NEW YORK

BUFFALO 14228-1035
(716) 574-2292
NEW YORK CITY
(888) 269-6755
SYRACUSE 13057-9313
(315) 432-0281

NORTH CAROLINA

CHARLOTTE 28273-3552
(704) 588-3251
RALEIGH 27540-9649
(704) 301-0565

NORTH DAKOTA

Contact MINNEAPOLIS, MN
(763) 391-8384

OHIO

AKRON
(216) 383-2662
CINCINNATI 45242-3706
(513) 554-4440
CLEVELAND 44117-2525
(216) 383-2662

COLUMBUS 43221-4073

(614) 488-7913
TOLEDO 43551-1914
(419) 874-6331

OKLAHOMA

OKLAHOMA CITY 73139-2432
(405) 616-1751
TULSA 74146-1622
(918) 622-9353

OREGON

Contact VANCOUVER, WA
(360)693-4712

PENNSYLVANIA

PHILADELPHIA 19008-4310
(610) 543-9462
PITTSBURGH 15001-4800
(724) 857-2750
HARRISBURG 17104-1422
(717) 213-9163

RHODE ISLAND

Contact BOSTON MA
(508) 788-9353

SOUTH CAROLINA

FLORENCE 29063-8468
(803) 331-4340

SOUTH DAKOTA

Contact MINNEAPOLIS, MN
(763) 391-8384

TENNESSEE

KNOXVILLE
(423) 612-1204
MEMPHIS 38119-5811
(901) 683-6260
NASHVILLE 37228-1708
(615) 291-9926
TRI-CITIES 37659-5693
(423) 612-1204

TEXAS

DALLAS 76051-7602
(817) 329-9353
HOUSTON 77060-3143
(281) 847-9444
SAN ANTONIO 78258-4009
(210) 393-9337

UTAH

MIDVALE 84047-3759
(801) 233-9353

VERMONT

Contact BOSTON MA
(508) 788-9353

VIRGINIA

LEESBURG, VA 20176-4113
Washington, D.C.
(703) 904-7735
DANVILLE 24541-6785
(434) 441-0227
HAMPTON ROADS 23455-7216
(757) 870-5508

WASHINGTON

VANCOUVER 98661-8023
(360) 693-4712
SPOKANE 99005-9637
(509) 953-7399

WASHINGTON DC

LEESBURG, VA 20176-4113
(703) 904-7735

WEST VIRGINIA

BARBOURSVILLE 25504-9665
(304) 736-5600

WISCONSIN

GREEN BAY 54302-1829
(920) 435-1012
MILWAUKEE
(262) 650-9364

CANADA

ALBERTA

CALGARY
(403) 253-9600/
(877) 600-WELD
WINNIPEG
(204) 488-6398

BRITISH COLUMBIA

VANCOUVER
(604) 945-7524

MARITIMES

NEW BRUNSWICK
(506) 849-4474

MANITOBA

WINNIPEG
(204) 488-6398

ONTARIO

MISSISSAUGA
(905) 565-5600
TORONTO
(416) 421-2600/
(800) 268-6114

QUEBEC

MONTREAL
(450) 654-3121

International Headquarters

LATIN AMERICA

Miami, Florida U.S.A.
Phone: (305) 888-3203

EUROPE

Barcelona, Spain
Phone: 34 91 816 4266

RUSSIA, AFRICA & MIDDLE EAST

Cleveland, Ohio U.S.A.
Phone: (216) 481-8100

ASIA PACIFIC

Shanghai
Phone: 86 21 6602 6620
Australia
Phone: 61 2 9772 7222

The Harris® Products Group

4501 Quality Place, Mason, Ohio 45040 U.S.A. • Web Site: www.harrisproductsgroup.com
Consumables: ph: 1-800-733-8912, fax: (513) 754-8778 • Equipment: ph: 1-800-241-0804, fax: (770) 535-0544

LINCOLN®
ELECTRIC
THE WELDING EXPERTS®

THE LINCOLN ELECTRIC COMPANY
22801 St. Clair Avenue • Cleveland, OH • 44117-1199
PH: 216-481-8100 • www.lincolnelectric.com